

CPU General Purpose Execution Environment (Linux)

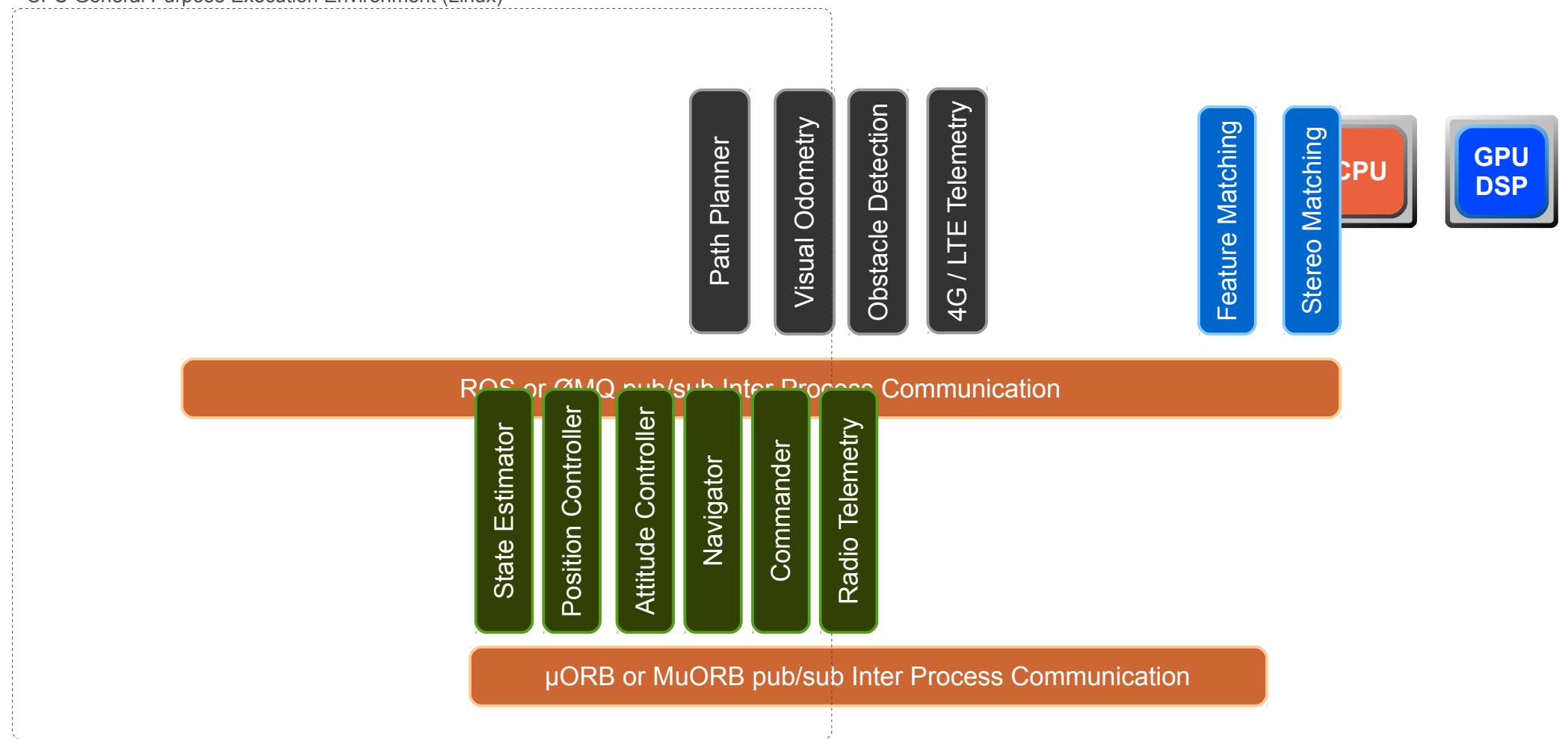

Microcontroller / DSP Realtime Execution Environment (RTOS)

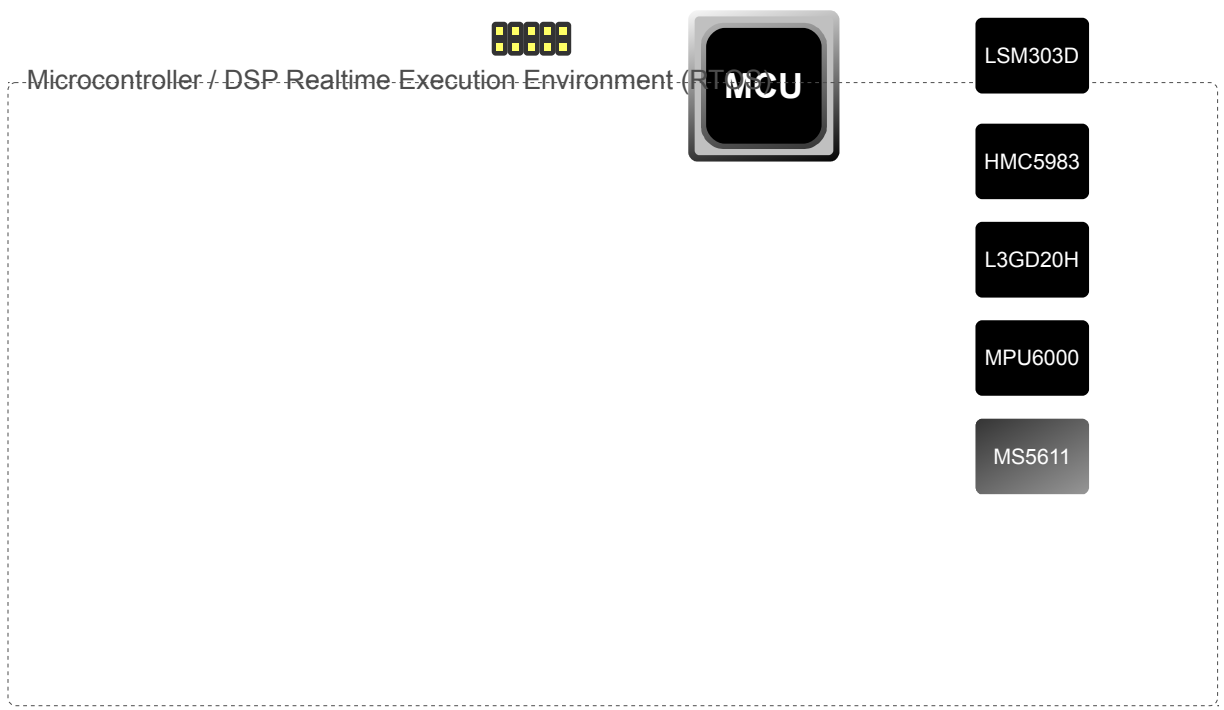

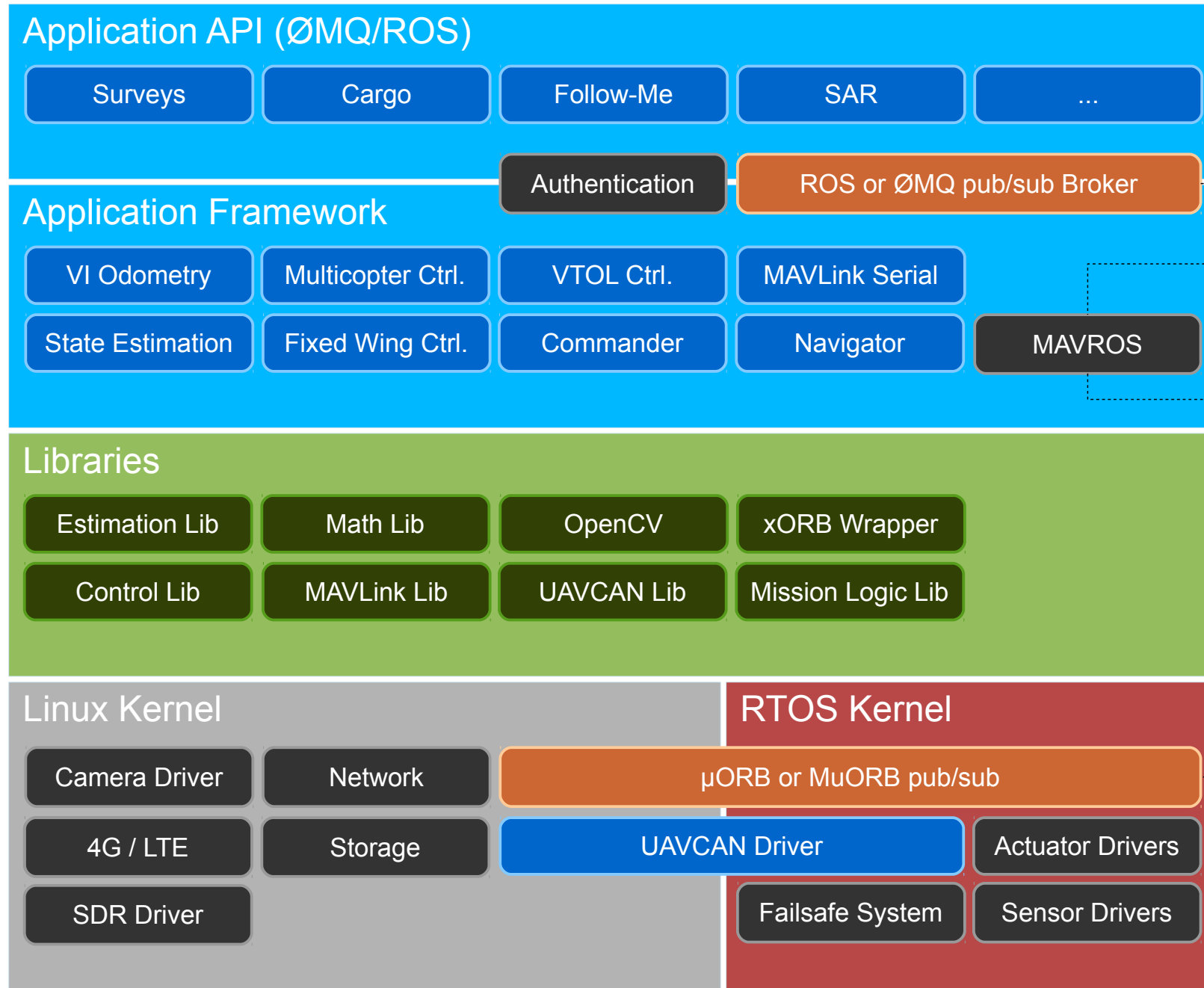

Groundstation on Tablet PC

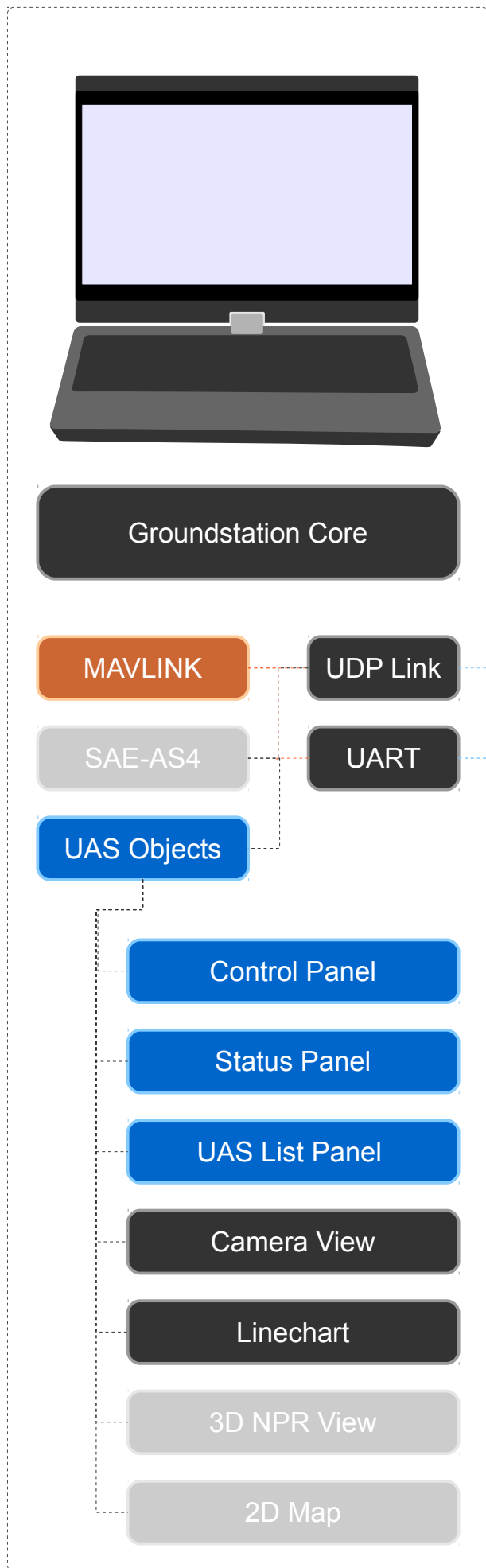

Gumstix Overo Fire / COMExpress board

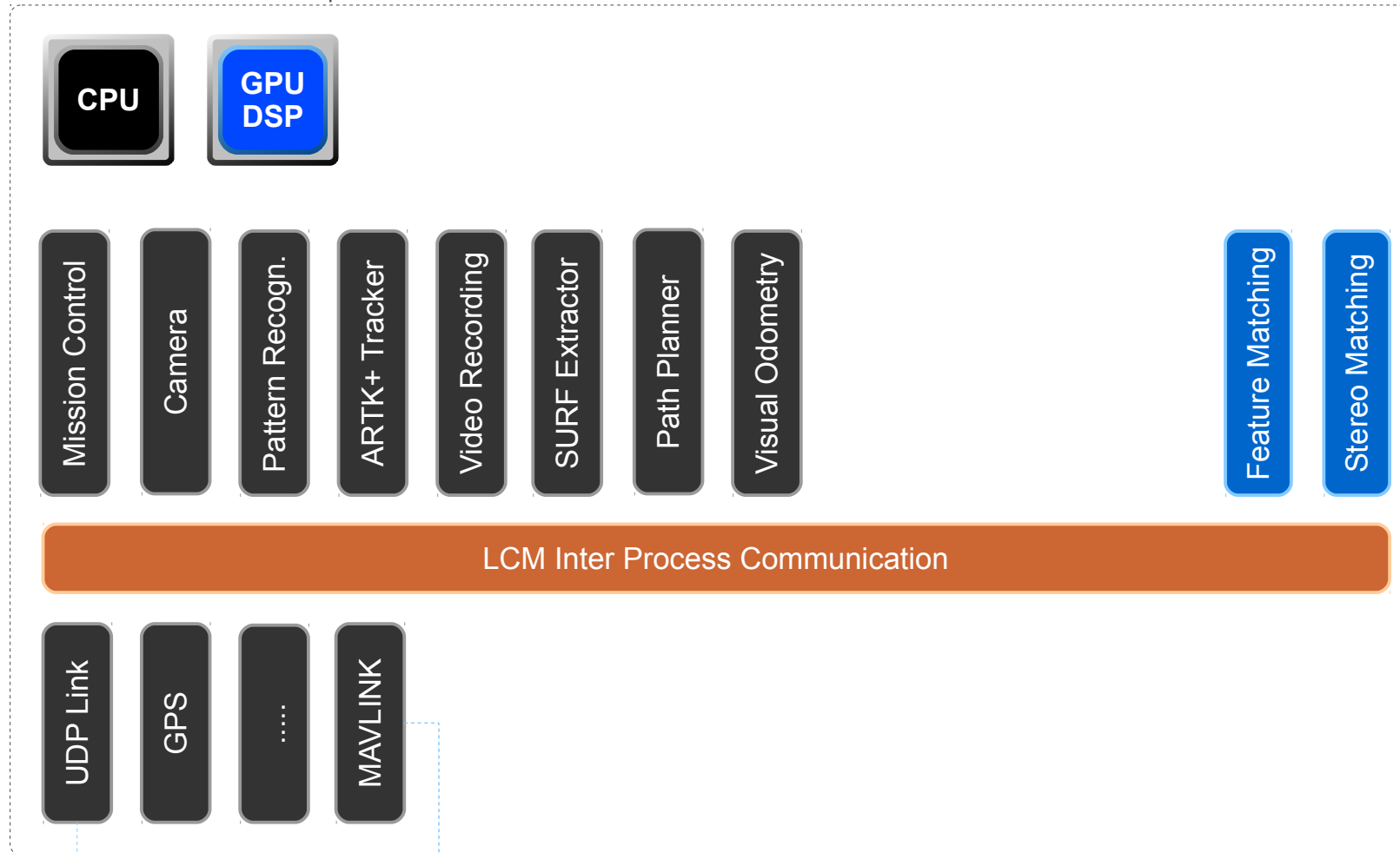

PIXHAWK flight board

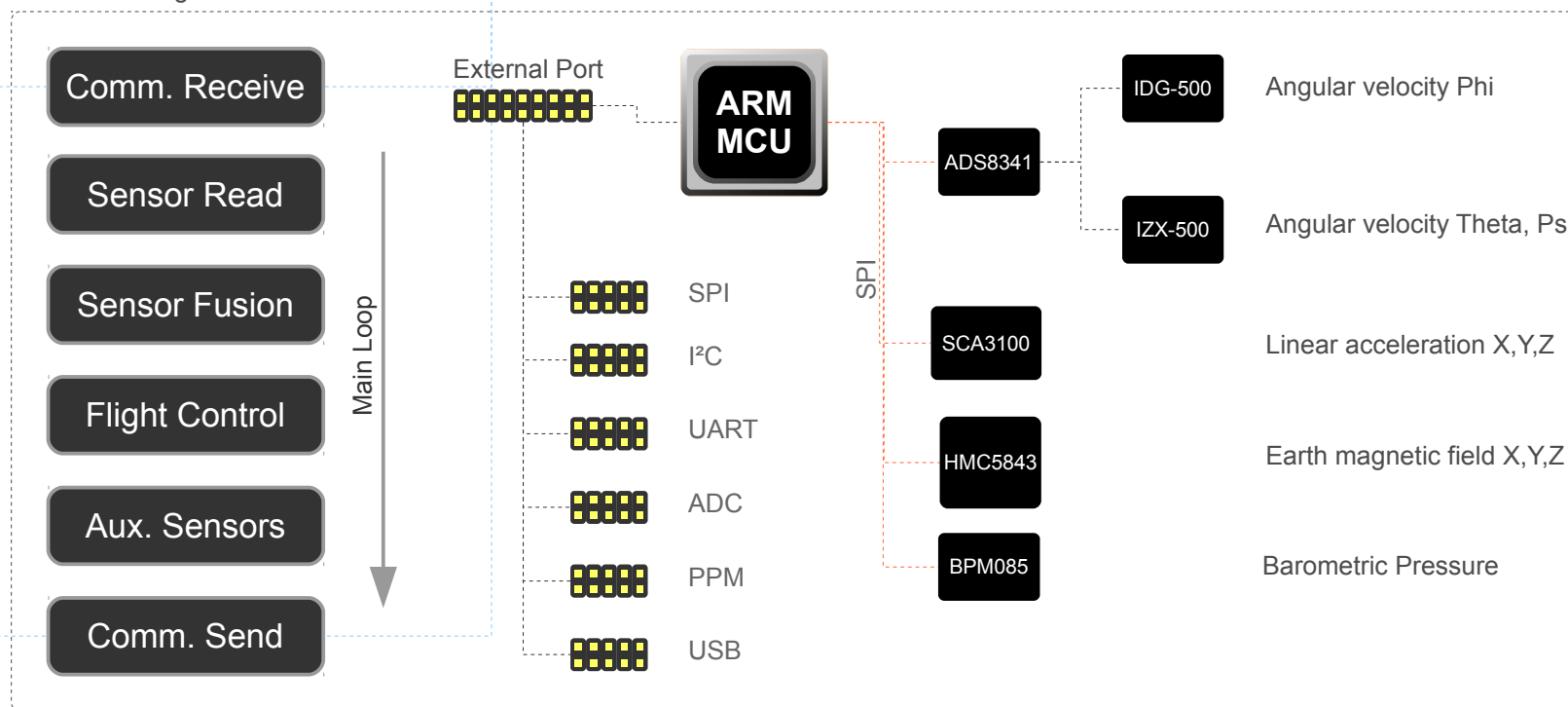

MAVLINK/SAE-AS4
over Wifi

MAVLINK
ZigBee

MAVLINK
UART

Main Loop

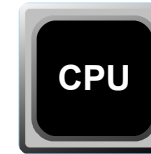
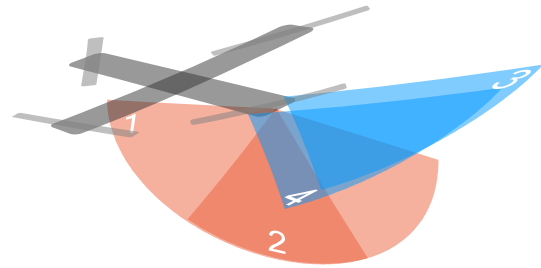

Camera 1
5-point
180°



Camera 2
5-point scale
60° / 4.0 mm



Camera 3
Stereo left
60° / 4.0 mm

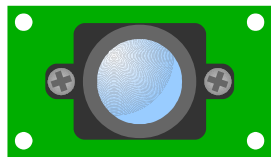

Camera 4
Stereo right
60° / 4.0 mm

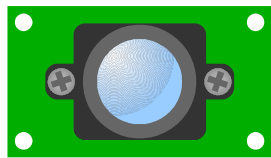

LCM Camera Hub

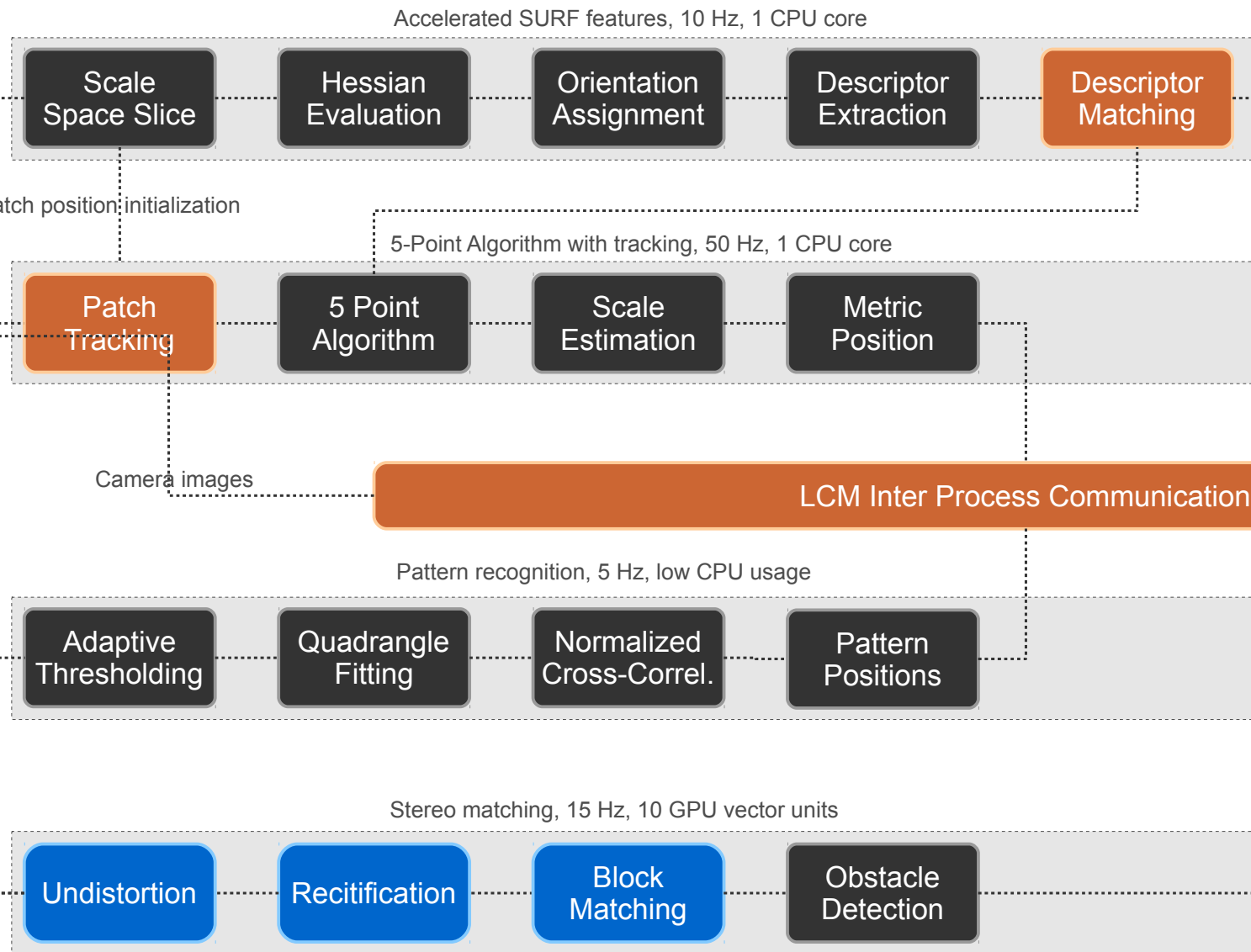

Matched features

State Estimator

FastSLAM

Position Controller

RRD Path Planner

Motor Interface

Obstacles

Ground Control Station

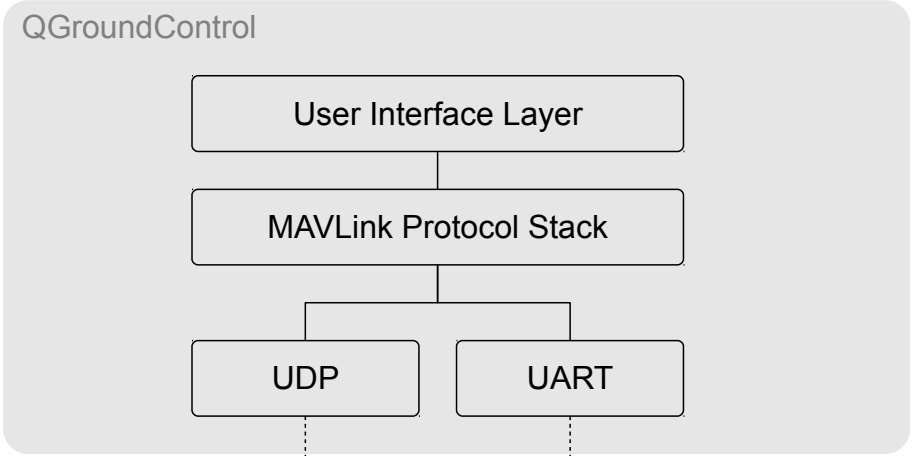
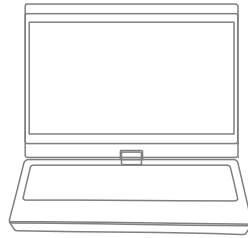

MAVLink

Computer Vision System

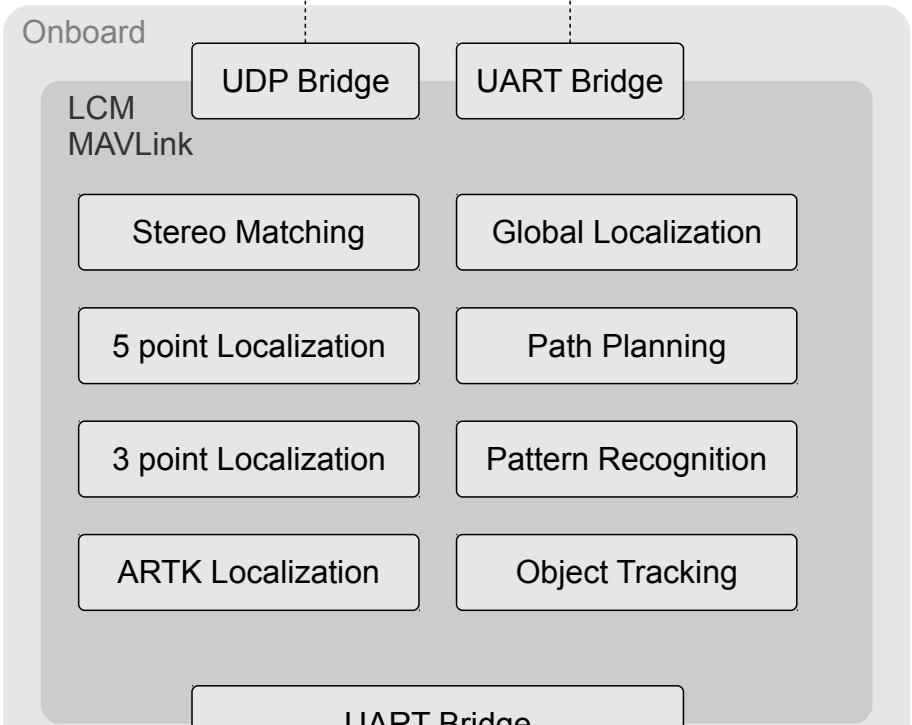
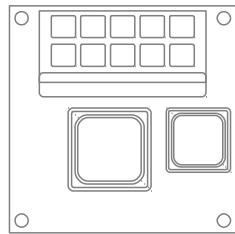

Autopilot

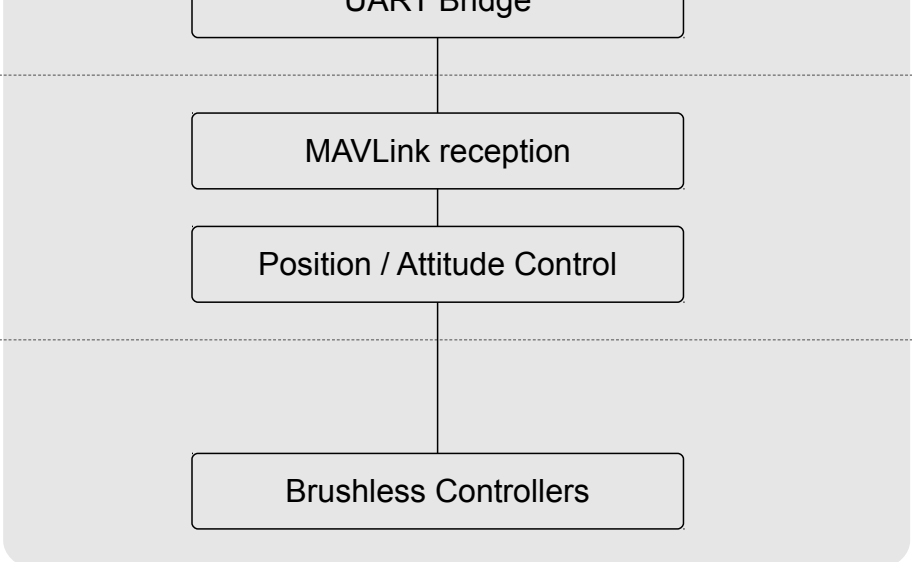
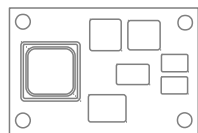

Motor Control

